

TORX
PROFESSIONAL LINE

BENCHASX9.5

MULTI FUNCTIONAL BENCH



BENCHASX9.5

The unique horizontal rail design gives the bench the ability to move flexibly and greatly expands the training range. Whether it's seated rowing, chest press, leg press or rowing, the movements are smoother and more natural. The cushion adjustment can be operated with one hand, allowing you to quickly switch between different angles. This greatly improves training efficiency, ensures a continuous rhythm without interruption, and helps you unlock a more professional and diverse dynamic training experience.

FLEXIBLY

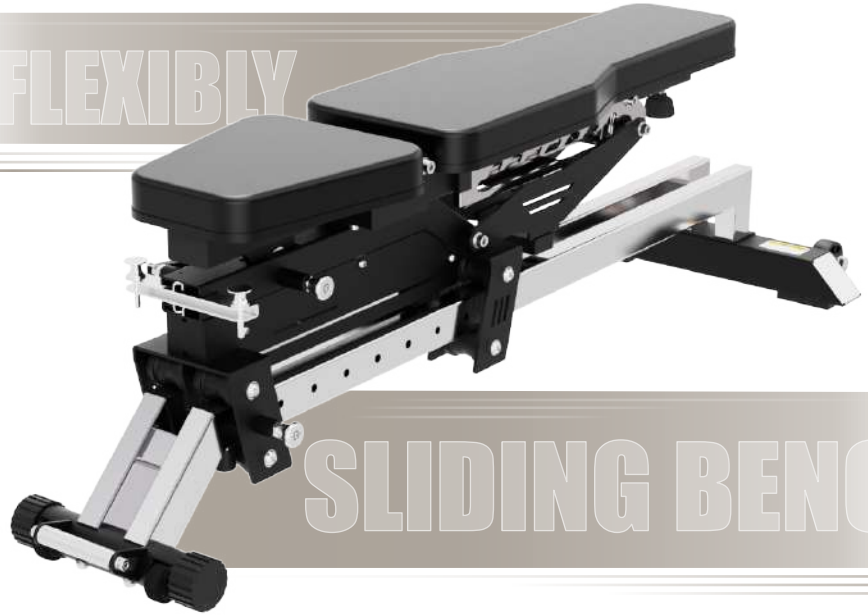

SLIDING BENCH

The footprint is roughly 1.10m²

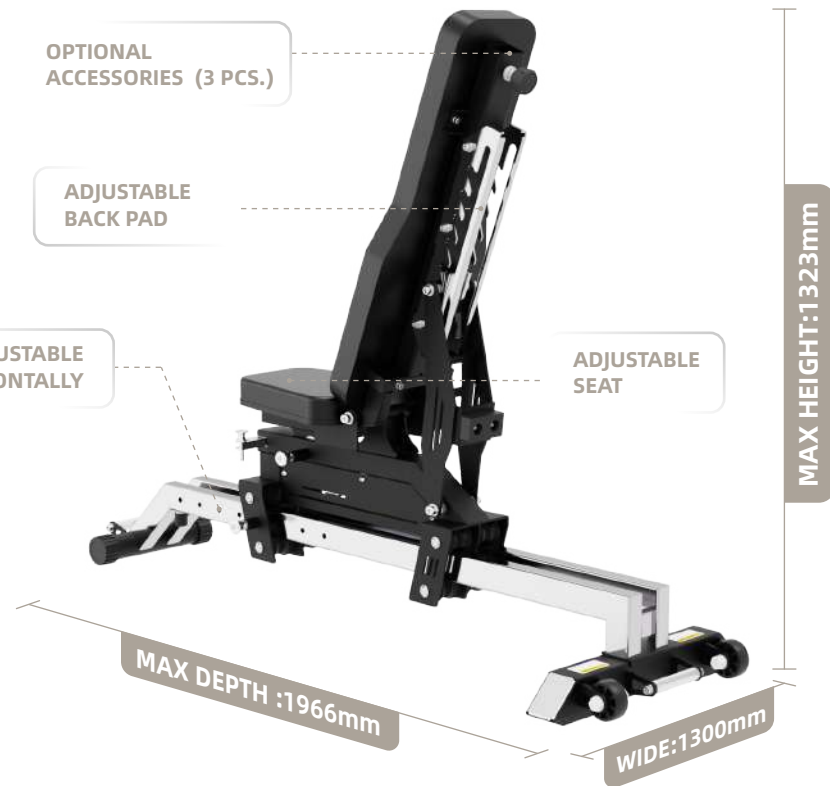

HORIZONTAL ADJUSTMENT

For exercises like the “leg press” or “seated row”, the sliding bench provides a greater range of motion, allowing you to perform movements more naturally. This flexibility helps target muscles more effectively and improves your form and technique.

4 POSITIONS

8 POSITIONS

8 POSITIONS

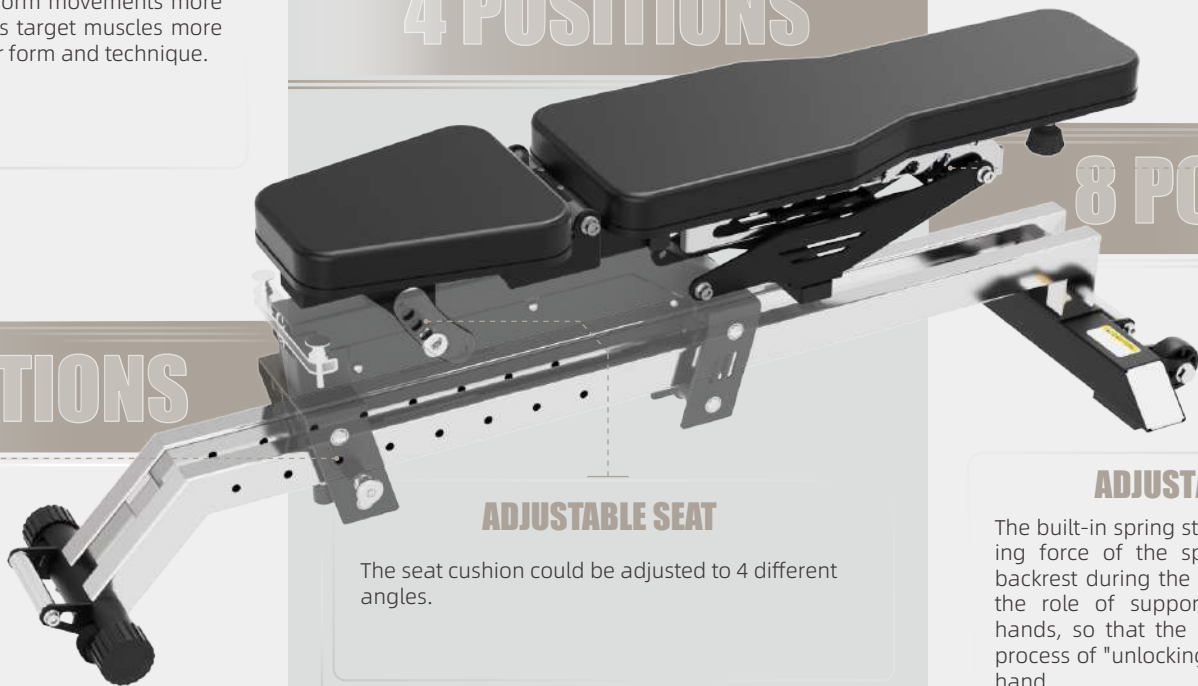

ADJUSTABLE SEAT

The seat cushion could be adjusted to 4 different angles.

ADJUSTABLE BACK PAD

The built-in spring structure uses the elastic clamping force of the spring to temporarily “fix” the backrest during the adjustment process, replacing the role of support when adjusting with both hands, so that the user can complete the whole process of “unlocking-adjusting - locking” with one hand.

HORIZONTAL ADJUSTMENT

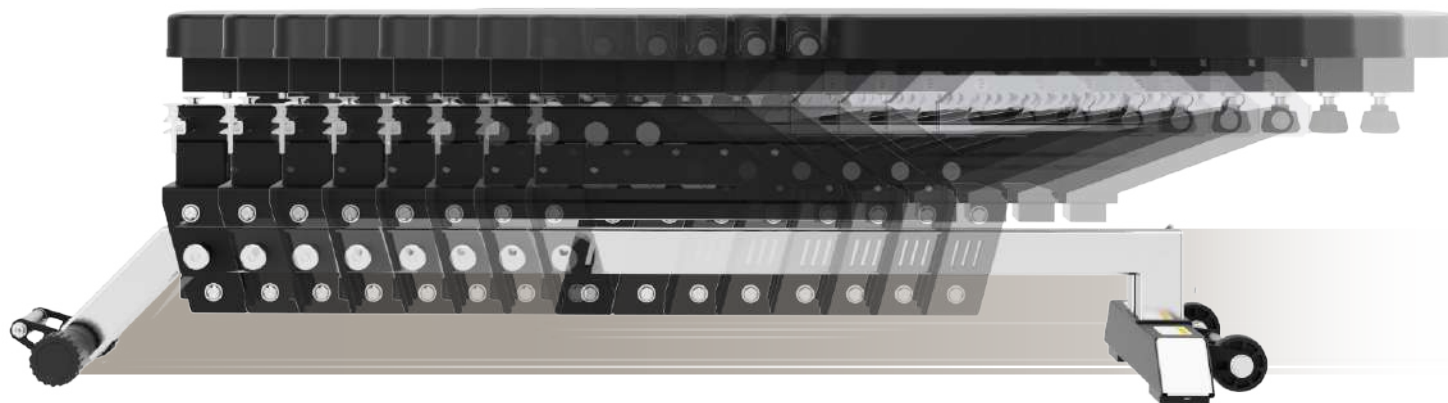

Wheels for easy transport and storage (Wheels on both front and rear stabilizer) .

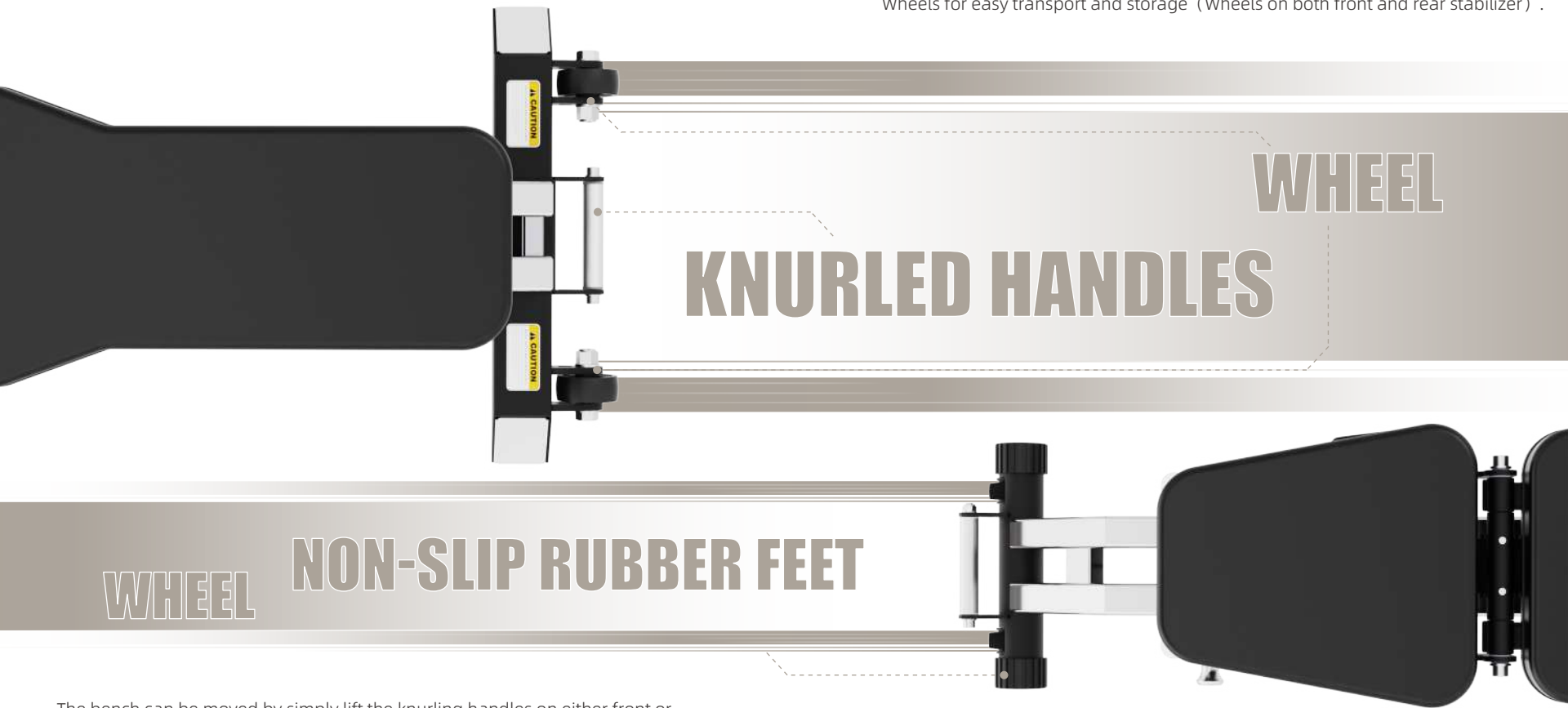

The bench can be moved by simply lift the knurling handles on either front or

rear.



ADJUSTABLE SEAT

ADJUSTABLE BACK PAD

With the set of shoulder pads for hack squats, the B70 Sliding Bench elevates your lower body workout. The attachment ensure a safe, comfortable, and effective workout, adding a plethora of exercises to your leg day routine.



OPTIONAL ACCESSORIES

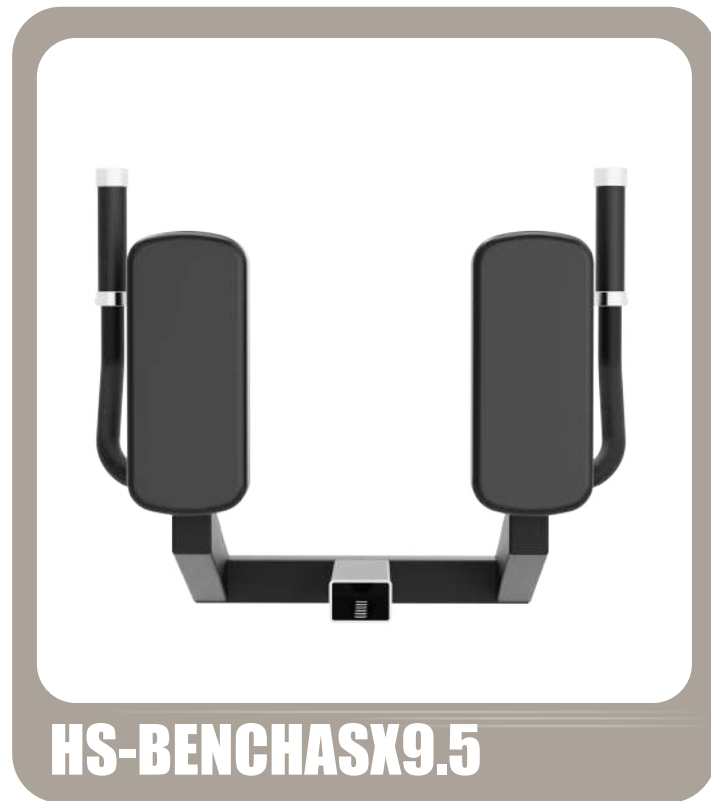

HS-BENCHASX9.5

OPTIONAL ACCESSORIES



DL-BENCHASX9.5



- (1) BELT SQUAT: ensure sufficient squat depth to assist in exerting force
- (2) STRAIGHT-LEG DEADLIFT: ensure sufficient deadlift depth to assist force
- (3) CENTRIPETAL ASSISTANCE OF THE BENCH: During the bench leg pushing movement, ensure that the leg muscles maintain the force state throughout the whole process.

OPTIONAL ACCESSORIES

OPTION

1



OPTION

2

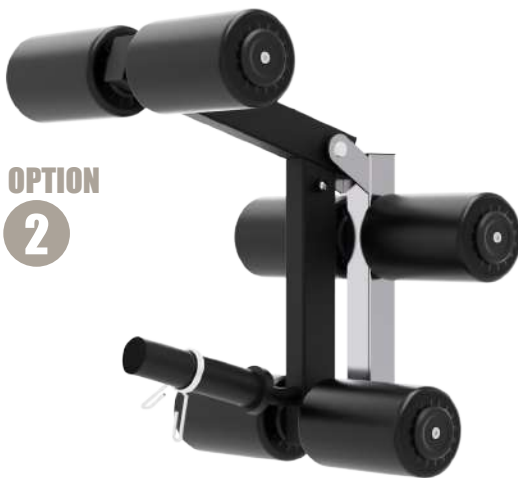

OPTION

3



ALC-BENCHASX9.5

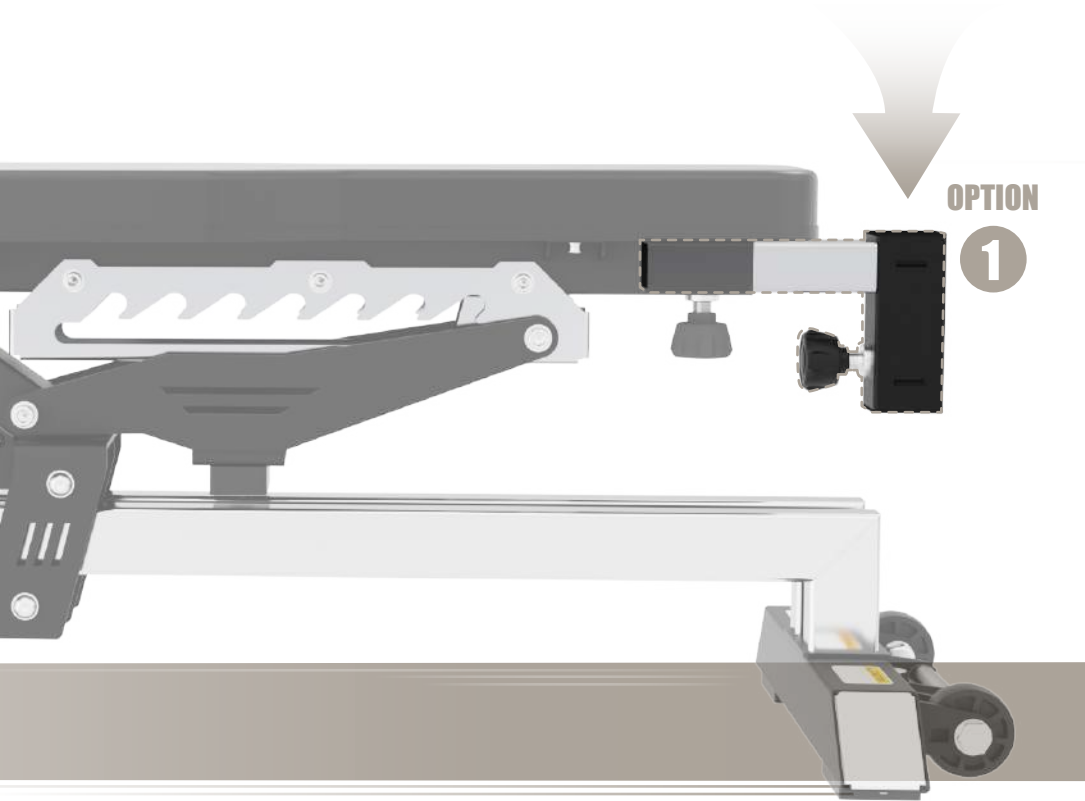

Install Option 1 first and then choose Option ② or Option ③ to workout.

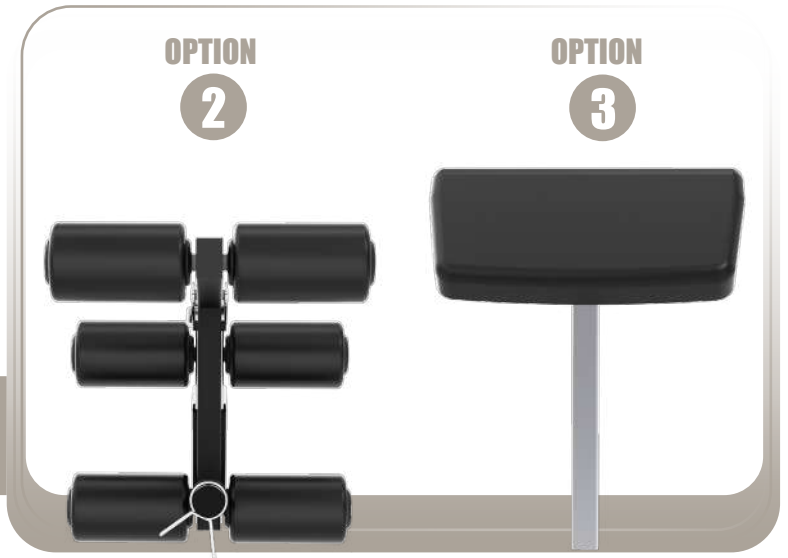



With leg curl and extension attachment, you can perform additional lower body movements with precision. This feature is perfect for sculpting your quads, hamstrings, and calves, ensuring a balanced and comprehensive workout.

The additional preacher curl attachment opens up a range of upper-body exercises. Ideal for cable-loaded bicep curls using the attachments .

